

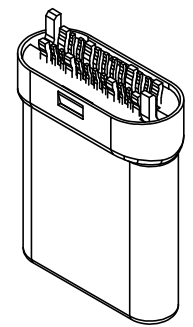

REV	DESCRIPTION	DATE	APPROVED
A	新版发行	2023. 01. 06	HHM

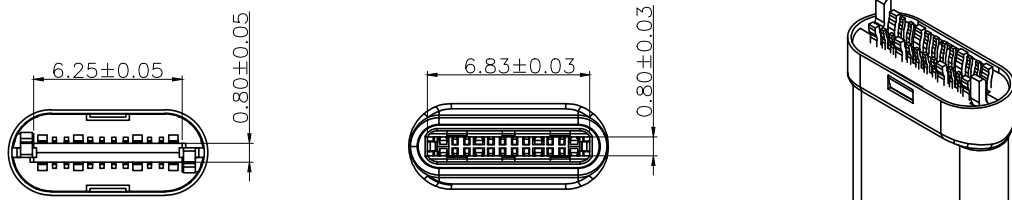

- NOTES:
- Material:SEE TABLE1;
 - Plating specification,
 - Contact:
Contact area: Ni50u"Min/Au See Table3;
Solder area: Ni50u"Min/Sn100u"Min.
Other area: Ni 50u"Min.
 - Shell: Ni50u"~150u";
 - Latch:
Solder area: Ni50u"Min/Sn100u"Min.
Other area: Ni 50u"Min.
 - Mechanicl Performance ,
 - Insertion Force:5~20N;
 - Extraction Force:8~20N after 10000 cycles;
 - Durability:10000 cycles.
 - Electrical Performance,
 - Insulation Resistance:100MΩ Min.
 - Contact Resistance :50mΩ Max.
 - Dielectric Strength :100V AC.
 - Current:15A .
 - The product accords with ROHS STD.

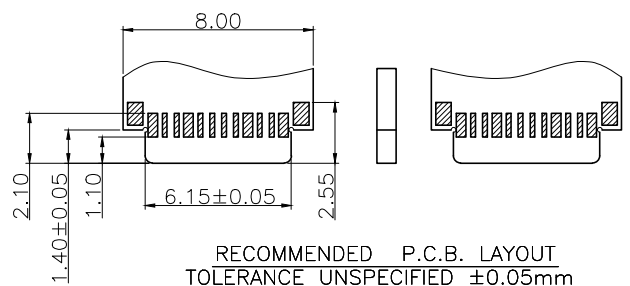
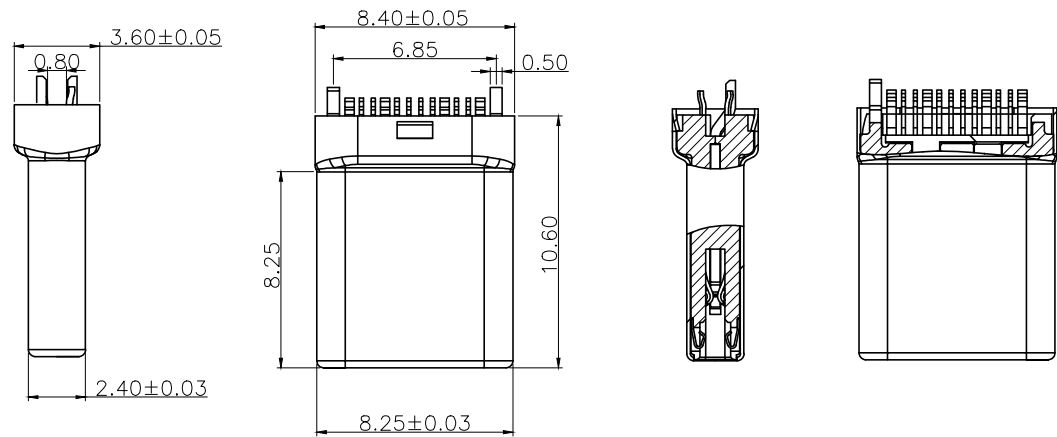

TABLE1:

NO.	NAME	DESCRIPTION
6	EMC SPRING	Stainless Steel;SUS301, T=0.08mm;
5	CONTACT-2	Copper Alloy;AuNiSn;T=0.15mm(Signal)
4	CONTACT-1	Copper Alloy;AuNiSn;T=0.25mm(Current)
3	LATCH	Stainless Steel;SUS301, T=0.40mm;
2	HOUSING	LCP Thermoplastic, UL94V-0;
1	SHELL	Stainless Steel;SUS316L, T=0.15mm;

TABLE2:
PINS DESCRIPTION,ONLY USED FOR 3.1 SERIES.

A12	A11	A10	A9	A8	A7	A6	A5	A4	A3	A2	A1
GND	RX2+	RX2-	VBUS	SBU1	D-	D+	CC	VBUS	TX1-	TX1+	GND
GND	TX2+	TX2-	VBUS	Vconn			SBU2	VBUS	RX1-	RX1+	GND
B1	B2	B3	B4	B5	B6	B7	B8	B9	B10	B11	B12

CUSTOMER DRAWING			铭创科技(东莞)有限公司 Mingchuang Technology (Dongguan) Co., Ltd.		
UNITS mm	SCALE 1:1	SHEET 1 OF 1	TITLE TYPE C公头24PIN 夹板0.8 L=10.6 15A大电流 拉伸 有台阶		
PROJECTION: 	DRAW: DAP		MAT'L SEE TABLE	FINISH SEE TABLE	
GENERAL TOLERANCE 0. ±0.35 0.0 ±0.25 0.00 ±0.15 0.° ±4° 0.0° ±3°	CHECK: HWT	APPD: HHM	DWG. NO. C18M2401A	PART NO. _____	SIZE A4