

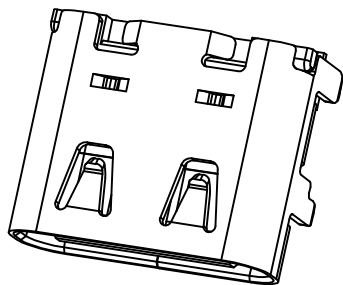

此位置为制程中折弯，  
对电镀层有损伤。  
不作盐雾判定标准

0.10



特性:

- 一、电气性能: ELECTRICAL
  - 1. 额定电流: 15A
  - 2. 接触阻抗: 40 MILLIOHMS MAX
  - 3. 耐电压: 100V AC / 1 mA MAX
  - 4. 绝缘阻抗: 150V DC/100 MEGA OHMS MIN

二、机械性能:

- 1. 插入力: 5~20N
- 2. 拨出力: 8~20N
- 3. 使用寿命: 10000次、拔出力 5N MIN

三、材料: MATERIAL

- 1. 外壳: SUS304 1/2H T=0.30mm
- 2. 中夹片: SUS301 3/4H T=0.20mm
- 3. 端子: C18400 H04 T=0.25mm
- 4. 塑胶: LCP+30%G/F黑色

四、电镀: FINISH

- 1. 端子整体镀镍50u"-150u";接触区镀金3u"±20% SMT焊区镀金G/F

- 2. 外壳镀镍: 50u"-150u"

- 五、电镀品需做粘锡测试: 粘锡面积达到95%以上。
- 六、SMT回流焊 (峰值260° C±5° C) 不能起泡、熔胶、变色不良 (变形在公差范围以内)

- 七、工作温度: -55° C~+85° C

八、盐雾测试:

通过24H在浓度为5±1%盐水的盐雾测试无生锈现象。

Suction

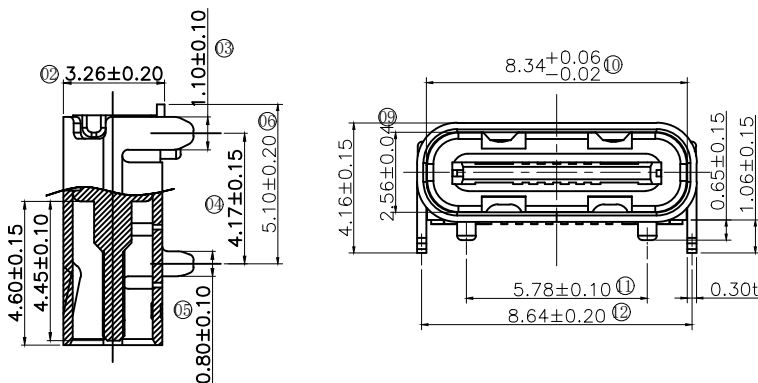
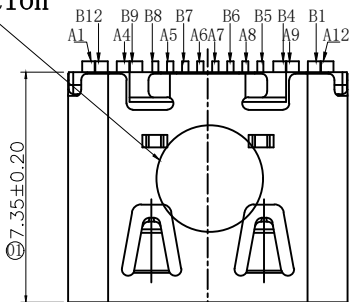

PIN针横切面，  
为电镀后制程切断，  
不作为盐雾判定标准

此区域镀金G/F

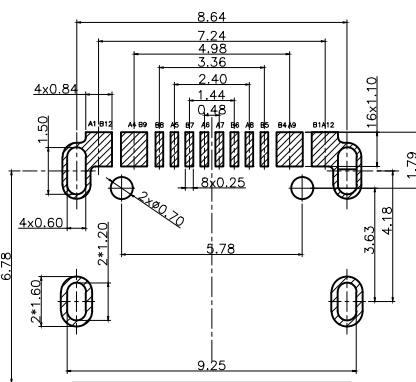
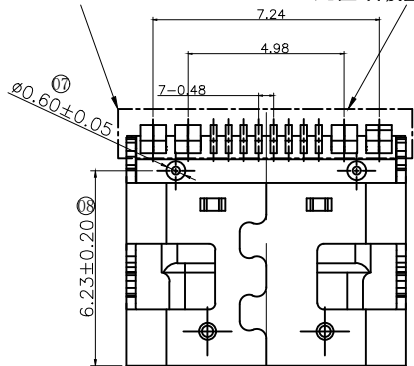

PCB EDGE  
RECOMMENDED P. C. B. LAYOUT  
TOLERANCE UNSPECIFIED ±0.05mm

A1	A2	A3	A4	A5	A6	A7	A8	A9	A10	A11	A12
GND	/	/	VBUS	CC1	D+	D-	SBU1	VBUS	/	/	GND
GND	/	/	VBUS	SBU2	D-	D+	CC2	VBUS	/	/	GND
B12	B11	B10	B9	B8	B7	B6	B5	B4	B3	B2	B1

CUSTOMER DRAWING

UNITS mm	SCALE 1:1	SHEET 1 OF 2
PROJECTION: 	DRAW: DAP	
GENERAL TOLERANCE 0. ±0.25 0.0 ±0.20 0.00 ±0.15 0.° ±4° 0.0° ±3°	CHECK: HWT	APPD: HHM

铭创科技 (东莞) 有限公司 Mingchuang Technology (Dongguan) Co., Ltd.		
TITLE TYPE C母座16PIN 板上四脚插板SMT L=7.35 15A大电流		
MAT'L SEE TABLE	FINISH SEE TABLE	
DWG. NO. A051601A	PART NO.	SIZE A4



REV	DESCRIPTION	DATE	APPROVED
A	新版发行	2024. 10. 18	HHM

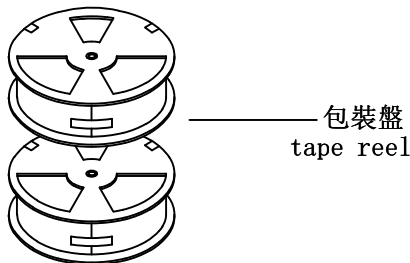
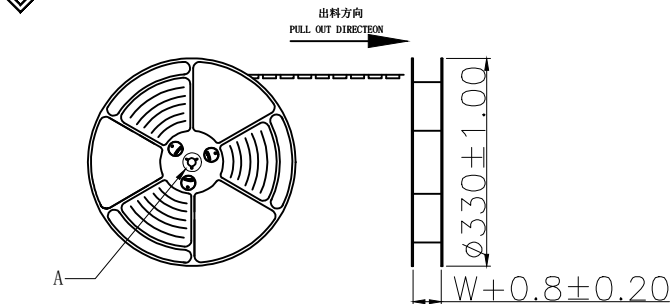

at small positioning hole of the carrier tape side).  
 标签黏贴处 (朝捲裝包材的小定位孔一側)  
 Location of label sticking (label)

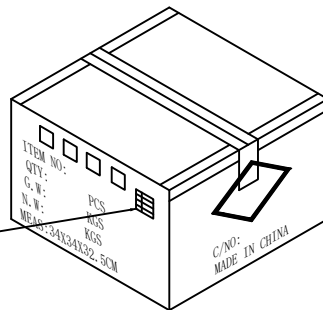
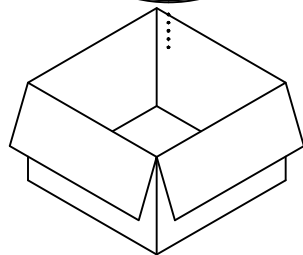
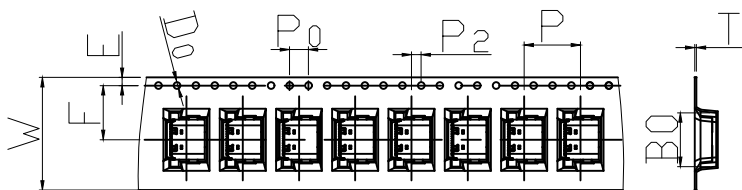
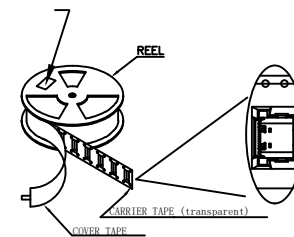

NOTE:

- 每捲包裝數量及每箱裝箱數量如左下表格。  
Packing q'ty of each reel & carton as below table shown.
- 將裝滿產品的卷盤放入紙箱並以膠帶封口  
Put reels in the carton and use adhesive tape to seal up.

NOTES

- 帶子引導長度  
LEAD TAPE LENGTH  
出料方向  
PULL OUT DIRECTION



- 上帶 剝力力為: 0.1~1.3N(10.2gf~130gf)  
PEELING OFF FORCE OF TOP TAPE: 0.1~1.3N(10.2gf~130gf)  
出貨'運輸過程中一定注意:  
THIS REQUIREMENT SHOULD BE APPLIED AT SHIPMENT;  
卷帶在運輸過程中不能散開  
PEELING OFF SHOULD NOT BE ALLOWED DURING TRANSPORTATION

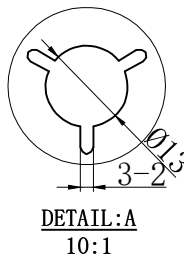
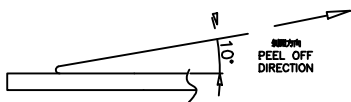

卷帶	規格: Ø330mm	包裝數量: 10000PCS
紙箱	規格: 340mmX340mmX325mm	包裝數量: 10盤(10000PCS)

W	24.00±0.3
AO	8.38±0.1
BO	11.46±0.1
KO	4.55±0.1
P	12.00±0.1
F	11.50±0.1
E	1.75±0.1
DO	1.50±0.1
P0	4.00±0.1
P2	2.00±0.1
T	0.35±0.1

CUSTOMER DRAWING			铭创科技(东莞)有限公司 Mingchuang Technology (Dongguan) Co., Ltd.		
UNITS mm	SCALE 1:1	SHEET 2 OF 2	TITLE TYPE C母座16PIN 板上四脚插板SMT L=7.35 15A大电流		
PROJECTION: 	DRAW: DAP	CHECK: HWT	MAT'L SEE TABLE	FINISH SEE TABLE	
GENERAL TOLERANCE 0. ±0.25 0.0 ±0.20 0.00 ±0.15 0.° ±4° 0.0° ±3°	APPD: HHM	DWG. NO. A051601A	PART NO. _____	SIZE A4	